

Portable Vertical Air-Conditioning and Heating Systems

Installation and Service Manual for 30 Ton Units—480V

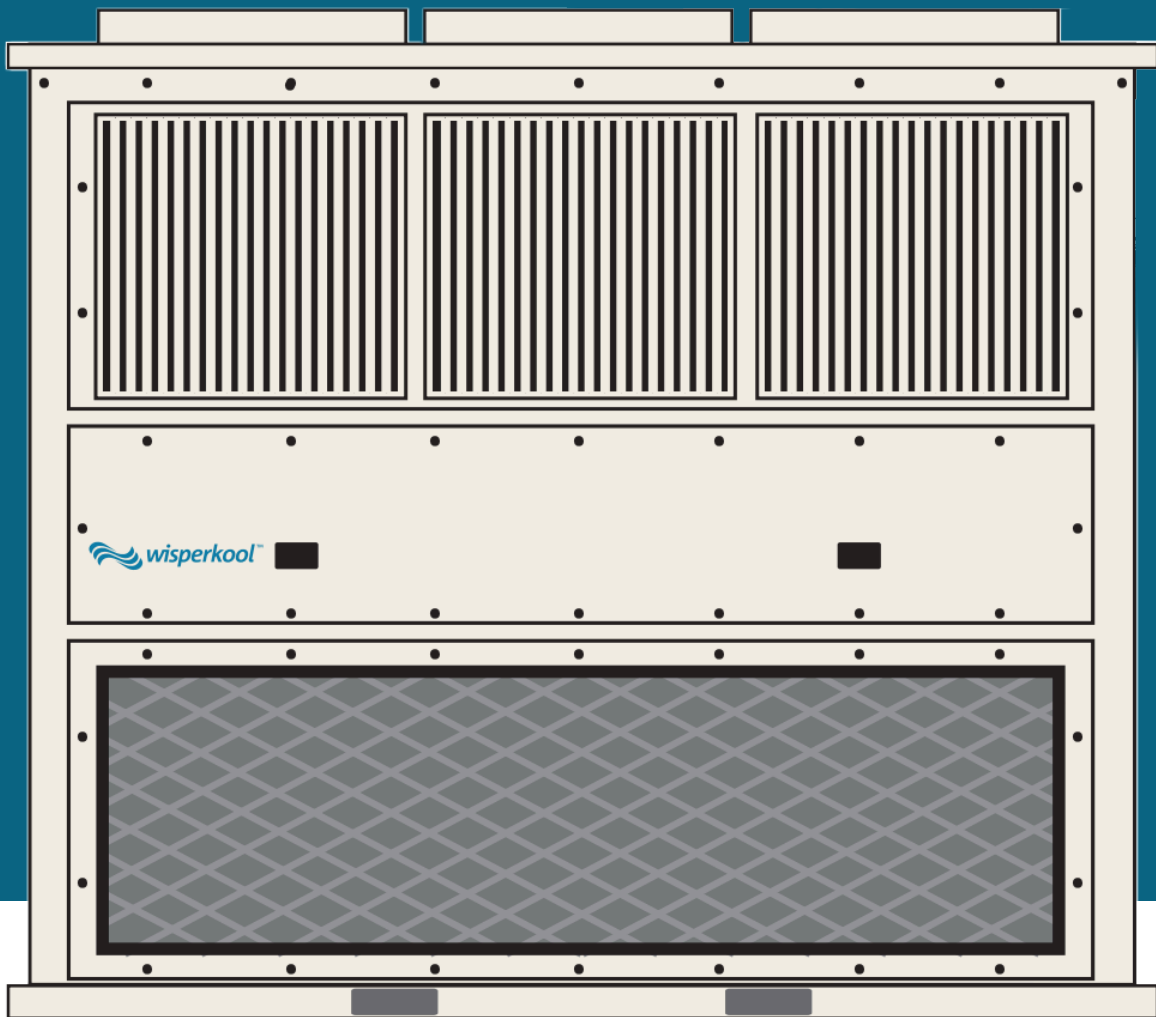

Table of Contents

Introduction	3
Warnings	4
General Information	5
Electrical Information	7
Start-Up Guidelines	10
Tent Installation	11
Fork Lift Pockets	12
Maintenance Guidelines	13

Introduction

This manual addresses the 30 ton **wisperkool™** HVAC unit for temporary cooling and heating solutions. This manual includes technical information, start-up information, and unit maintenance. The information contained in this manual is provided to ensure the safe installation and operation of the equipment. It is for reference only.



PLEASE READ ALL WARNINGS AND INSTRUCTIONS
CAREFULLY BEFORE AND DURING SET UP AND MAINTENANCE.



30 TON
480V

Warnings and Safety Protocols

Live Electrical Components

During installation, testing, servicing and troubleshooting of this product, it may be necessary to work with live electrical components. **A qualified licensed electrician or other individual who has been properly trained in handling live electrical components must perform these tasks.** Failure to follow all electrical safety precautions when exposed to live electrical components could result in serious injury or death.

Heavy Objects

Use a forklift of suitable capacity to move the unit. Failure to properly lift unit could result in death or serious injury or possible equipment or property damage

State and Local Codes

Failure to follow state and local codes could result in death or serious injury. All vertical HVAC units should be installed per the National Electric Code (NEC) and/or applicable state and local codes.

Voltage Rating

External Power must match voltage rating **480/3/60**. Do not exceed amp rating.

Tent Clamp Bolts

DO NOT OVER-TORQUE THE TENT CLAMP BOLTS. This could permanently damage the tent clamps rendering them ineffective. Clamps would need to be replaced. The warranty would not cover this.

Voltage

Disconnect all electrical power before servicing. Follow proper procedures to ensure that the power cannot be inadvertently turned on. Failure to disconnect power before servicing can result in serious injury or death.

The 30 ton wisperkool™ unit is  approved.

General Information

Vertical air conditioning units can be used in free blow or ducted applications. A separate set of supply and return duct adapters can be installed by removing the supply and return panels. Each unit includes a clamp on the top and each side for installation in the wall of a tent or a special event application.

Accessories such as flexible duct, electrical cable, supply and return air duct adapters and condenser discharge duct adapters are available upon request.

General Unit Information

30 TON

480V

Refrigerant	Type	410A
	Charge	15 lbs.
Compressor	Type	Scroll
	Quantity	2
	Nominal Tons	15
	Hot Gas Bypass	Yes
Evaporator Airflow	Orientation	Horizontal
	Nominal Airflow	9,500 cfm
	Max Static Discharge Pressure	1.18 high, 0.79 low
Supply Air Connections	Type	Grille or Duct
	Quantity	3
	Size	24 in. Grille / 20 in. Duct
Return Air Connections	Type	Grille or Duct
	Quantity	3
	Size	20 in.
Evaporator Coil	Rows	4
	Face Area	16.25 sq. ft.
	FPI	12
Condenser Coil	Rows	4
	Face Area	26 sq. ft.
	FPI	14
Filter	Type	Washable
	Quantity	3
	Dimensions	3-27.25 in. x 28 in. x 2 in.

Cooling Capacity (MHB)

Entering Air Temp		Temperature F (air over condenser)	
DB	WB	95°F	
		Total	Sensible
95	79	200	120

Note: Capacities are gross values and are not adjusted for motor heat.

Electric Heat Air Temperature Rise

Heater kW	Temperature Rise (F)
72	22° High / 28° Low

Note: Capacities are gross values and are not adjusted for motor heat.

Weights and Dimensions

Model	Length	Width	Height	Weight
30 Ton	95"	47"	86"	3507
Fork Pocket Dimensions		10"	3"	

Note: Add 17 inches to the unit width and 50 lbs. to the unit weight for condenser discharge duct connections.

Electrical Information

All 30 ton wisperkool™ air conditioning units are 480V, 3-phase, 60 Hz.

Each unit has eight color coded cam-type electrical connections. When connecting one unit to a power source the male cam-type connections on the top should be used. The bottom row female cam-type connections are only to be used when connecting multiple units to one power source and allows connecting several units in series. Either 2/0 or 4/0 electrical cable should be used. When connecting multiple units in series do not exceed amp rating of cable used. Exceeding amp ratings could cause permanent damage to the electrical cables.

Circuit Breaker	Yes
Maximum Over-current Protection (MCA) – cooling with heat	125 amps
Compressor RLA	18.8 amps
Evaporator Blower Motor	10 hp
Evaporator Blower RLA	5.3 amps
Condenser Blower Motor	2 hp
Condenser Blower RLA (each-3)	3.4 amps
Heater kW (total)	72 kW
Heater Amperage (total)	92
Heater kW Each Stage	35 kW and 37 kW
Heater Stages	2



**EXTERNAL POWER MUST MATCH VOLTAGE RATING 480/3/60
DO NOT EXCEED AMP RATING**

Electrical Information CONTINUED

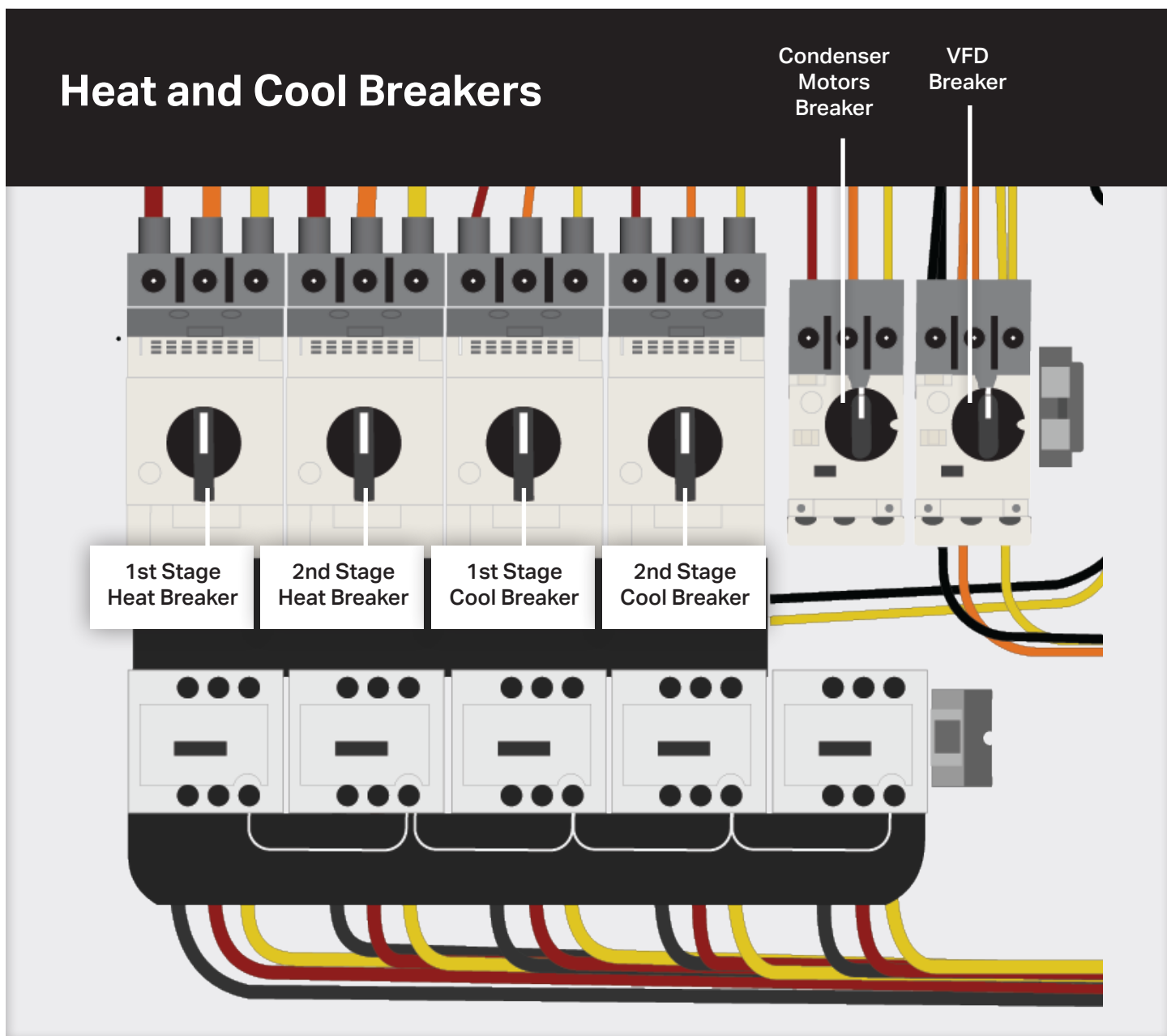

Line Drawings

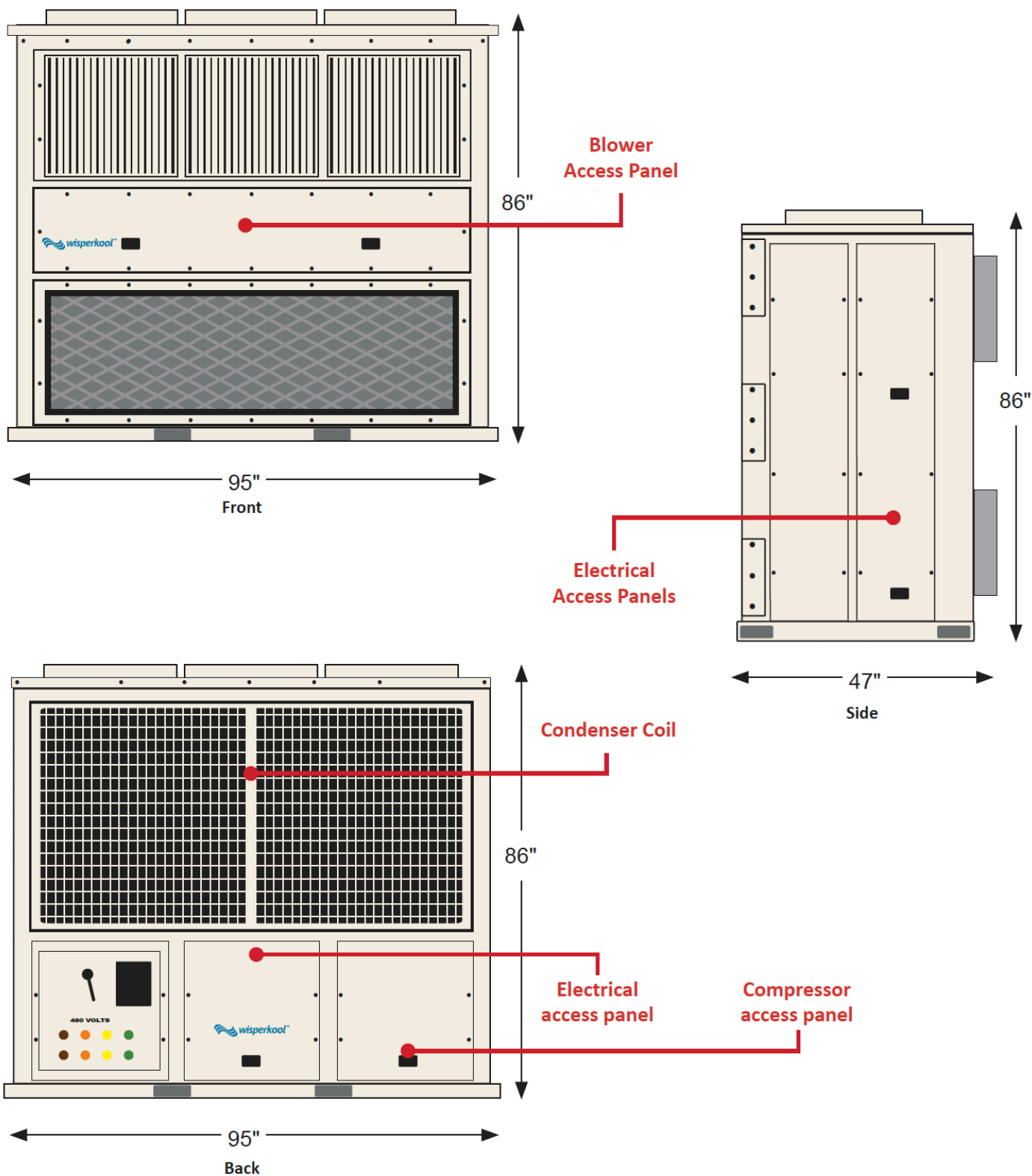

Start-Up Guidelines

Data Nab Controller

1. Once the power cables are attached turn the black power handle to the **ON** position.
2. The unit is preset to run on high cool at 72 degrees.
3. If the phase light is red, turn off the power and switch the positions of the first two power cords.
4. To lower the fan speed switch the fan control knob to **LOW**.
5. To manually raise or lower the temperature push the **^** or **v** symbols to get the desired temperature.
6. To switch the unit to heat press the **>** symbol on the right until you see the HVAC MODE appear.
7. Push the **^** or **v** arrow until the set point appears.
8. The heat is preset at 72 degrees.
9. To manually raise or lower the temperature push the **^** or **v** symbols to get the desired temperature.
10. To stop the unit turn the black power handle to the **OFF** position.
11. The wisperkool™ unit will restart at the same setting that was in place when shut down.



1



2



3



4



5



6

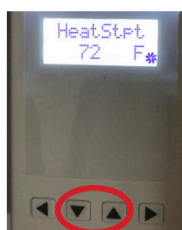

7-9



10

Tent Side Wall Installation

- Confirm that unit is properly leveled.
- Loosen tent clamps on top and sides of unit.
- Carefully slide the sidewall fabric under the tent clamps on each side and top of the unit.
- Tighten down the tent clamps using a $\frac{3}{4}$ -inch wrench or socket.

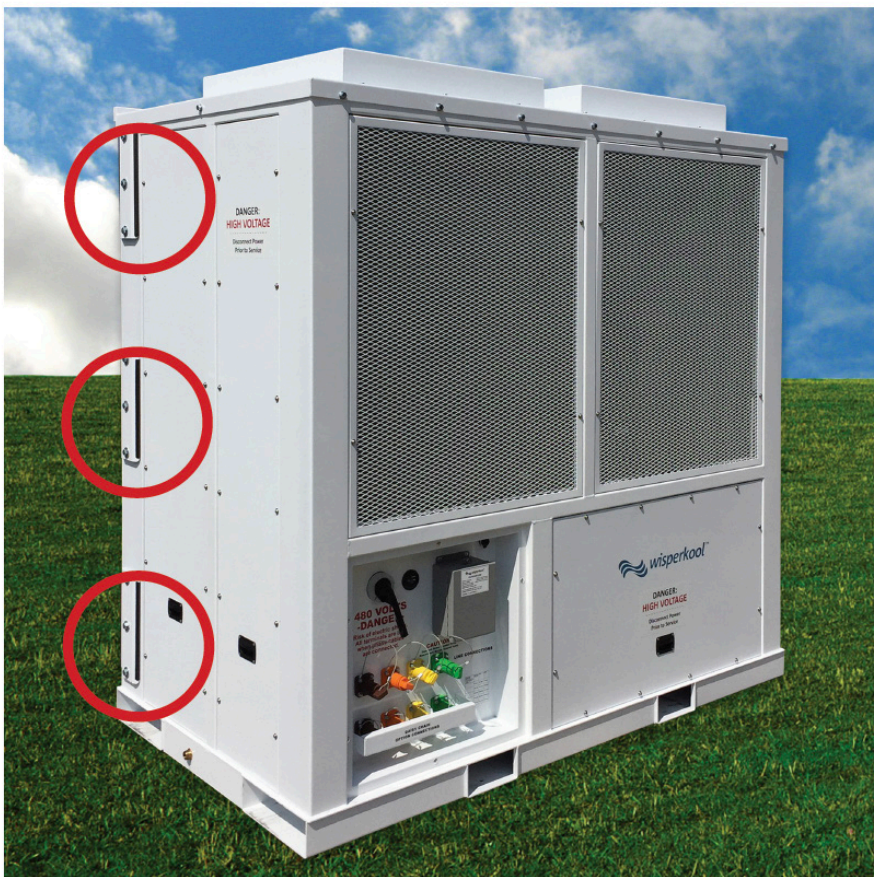

DO NOT OVER-TORQUE THE TENT CLAMP BOLTS.
THIS COULD PERMANENTLY DAMAGE THE TENT CLAMPS!

Fork Lift Pockets

Use a forklift of suitable capacity to move the unit. Failure to properly lift unit could result in death or serious injury or possible equipment or property damage.



WARNING!
HEAVY OBJECTS!

Maintenance Guidelines

The motor and blower bearings are permanently lubricated and should not require maintenance. The evaporator fans are belt driven. The drive belts should be routinely examined for wear and correct tension. An incorrectly tensioned belt can cause bearing or wear damage.

The belts can be tensioned by loosening the 4 bolts holding the motor to the motor mount. Once the motor mount bolts are loose, adjust the belts by tightening or loosening the two $\frac{3}{4}$ -in. adjusting bolts on the bottom of the motor mount bracket. Re-tighten the 4 bolts holding the motor to the motor mount.

A properly tensioned belt has approximately 1 in. to 1½ in. movement when both legs of the belt are pressed in midway between the pulley and the sheave.

Each unit is provided with replaceable filters that are installed in the evaporator return air section. The return air grill must be removed to gain access to the filters. Check filters periodically to verify that the filters are clean. Dirty filters will severely reduce the performance of the machine.



Motor Mount Bolt
 $\frac{3}{4}$ " adjusting bolt

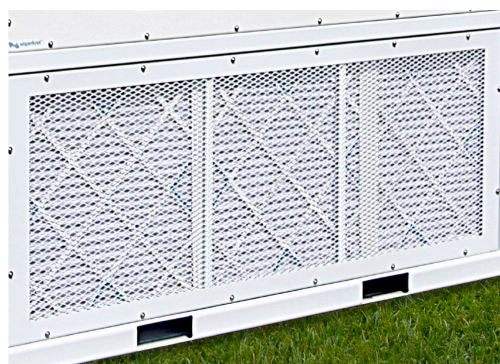

Washable filters are behind the return air grate



HAZARDOUS VOLTAGE!
DISCONNECT ALL ELECTRICAL POWER BEFORE SERVICING.

Follow proper procedures to ensure that the power cannot be inadvertently turned on. Failure to disconnect power before servicing can result in serious injury or death.